

Energy Savings on Centrifugal Fans and Pumps

Centrifugal loads..... : Affinity Law, otherwise known as Power Cubed Law, or Square Torque Law

States that: Power varies as speed cubed, or torque squared.

In other words: The power needed to turn a centrifugal load is proportional to the cube of rotational speed.

So: a 20% reduction in speed, gives a 50% reduction in power required.:

Energy Efficiency Office

Motors responsible for 64% of UK usage.

50% of motors installed on fans and pumps

Majority of motors on fans / pumps are oversized

80% speed = 50% energy

Fans - Energy Saving

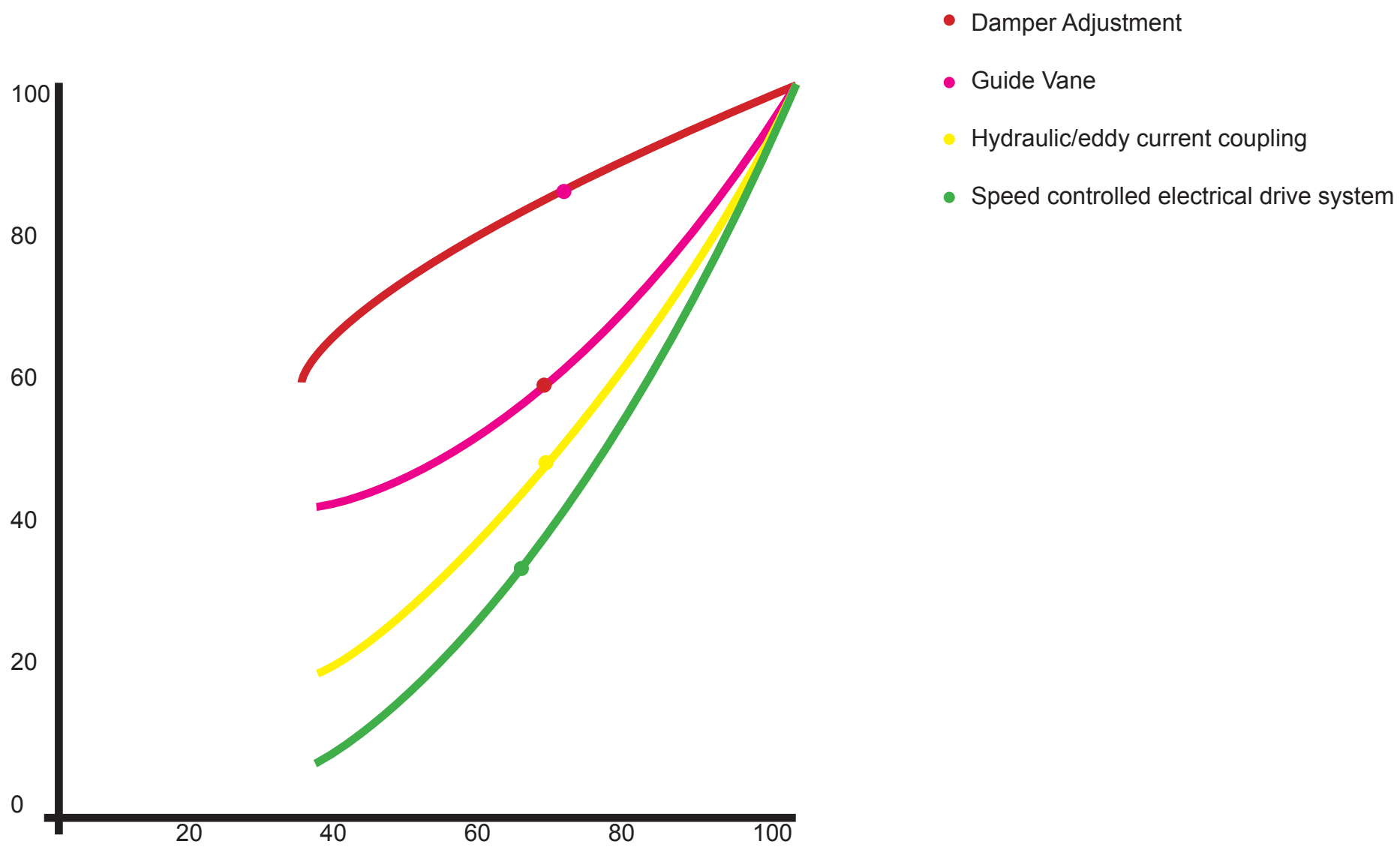

Pumps - Energy Saving

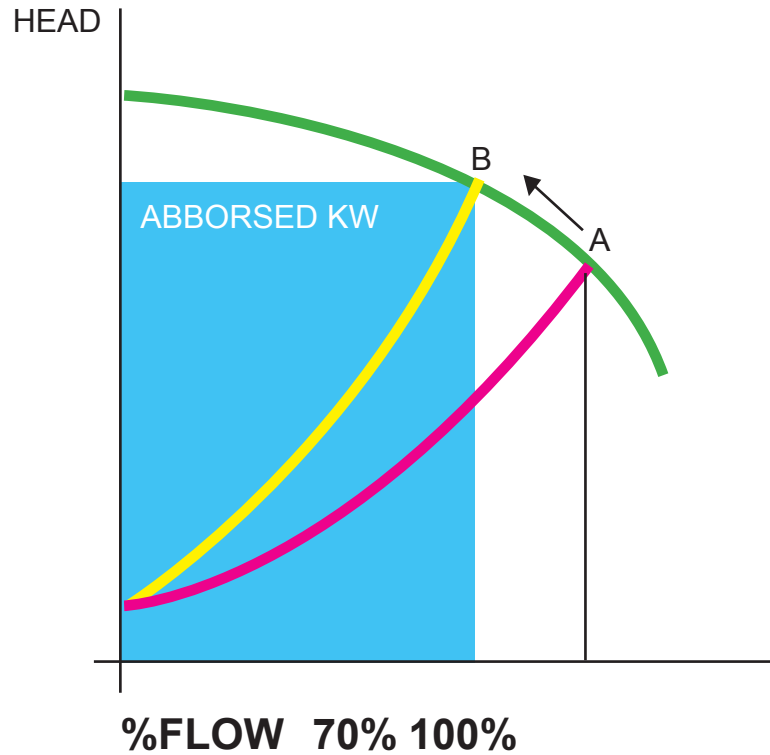

Control by Valve

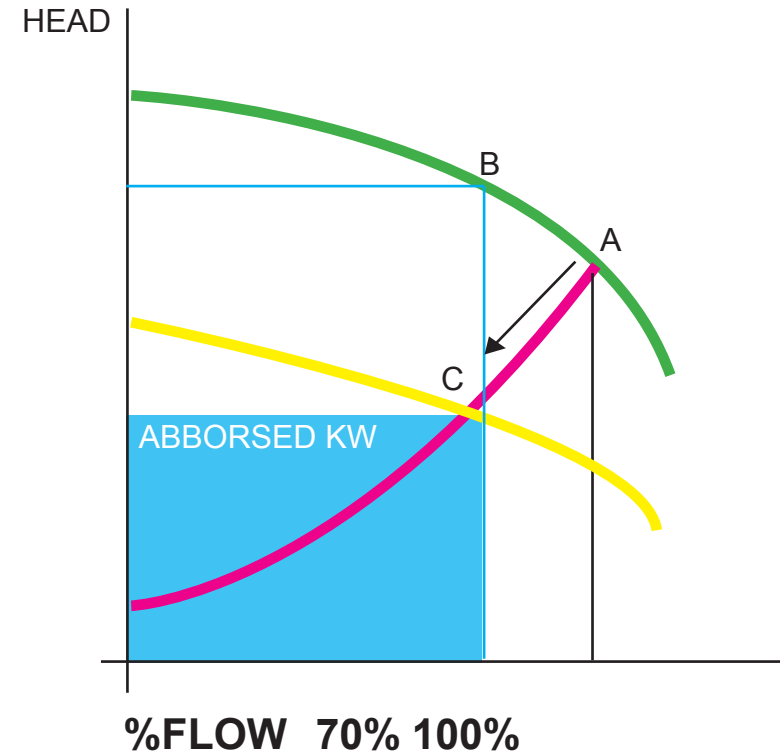

**Control by the VLT 3500
Frequency Converter**

VSD Based Closed Loop Cooling Water system

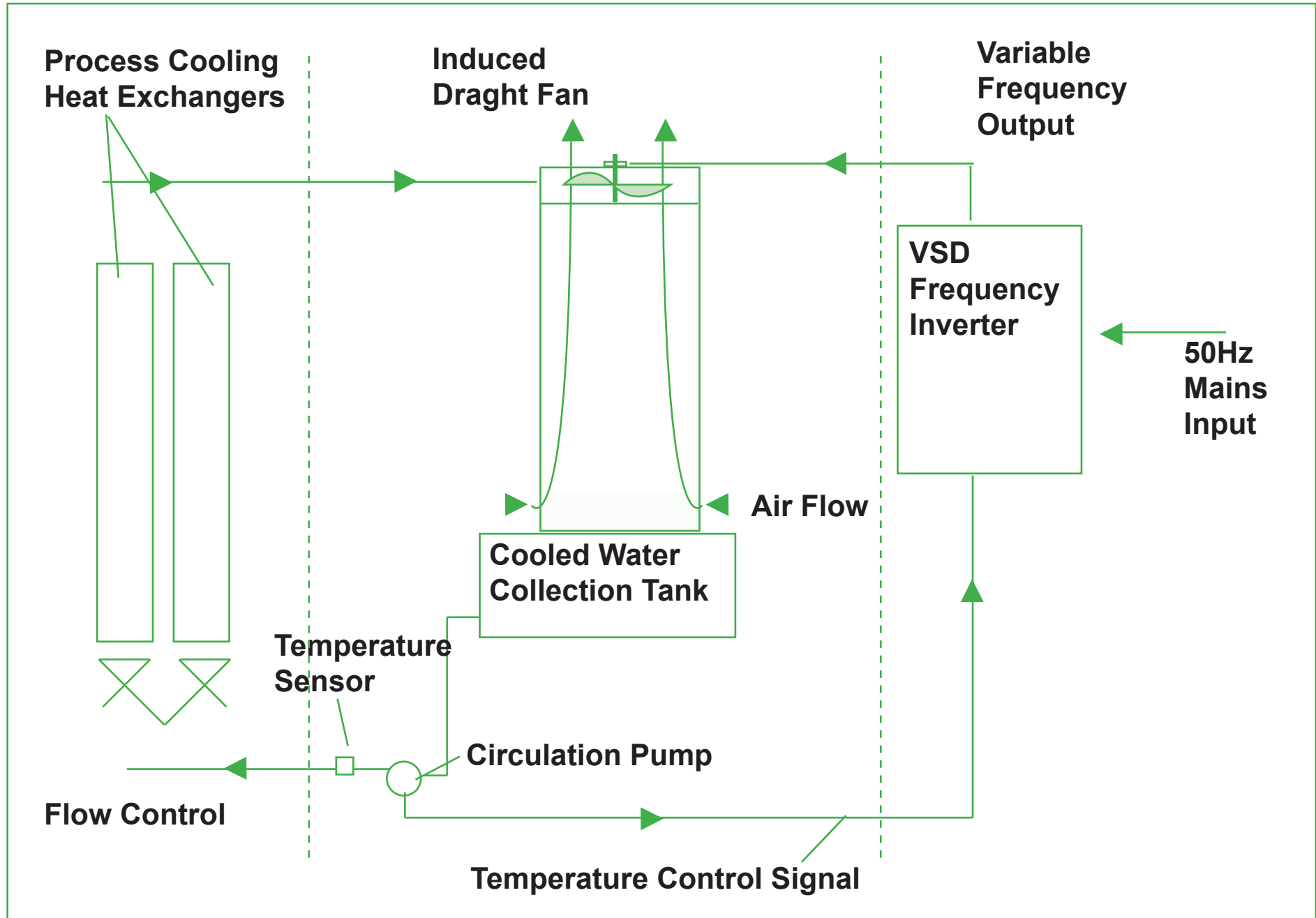

Closed Loop Temperature Control of the Return Water

Return Water Temperature °C	Inverter Output
< 14	Shut down
16	Restart
16-19	Speed increases proportionally
> 19	Full Speed

Comparison of Energy Consumption of the Fan with and without VSD

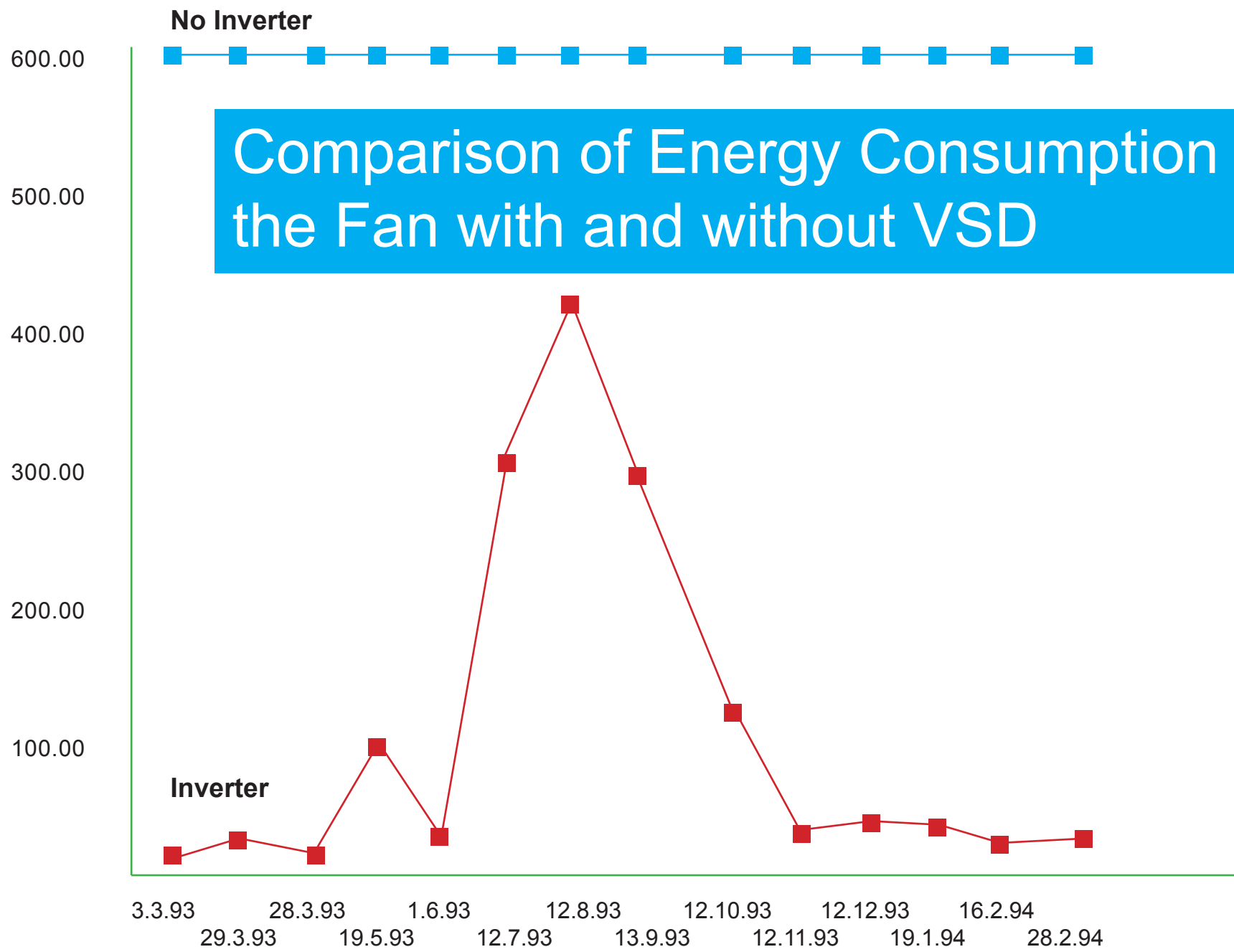

VSDs on a Cooling Tower Fan

Investment £5,400

Energy Savings £7,590 p.a

Payback 10.5 months